

# SETUP SHEET

## FOR THE RC10L3 Touring KIT

TEAM ASSOCIATED

DATE: \_\_\_\_\_  
 DRIVER: \_\_\_\_\_  
 TRACK LOCATION: \_\_\_\_\_  
 EVENT: \_\_\_\_\_

### FRONT SUSPENSION

UPPER ARM MOUNT:  0°  10°

CASTER SHIM POSITION:  
 rear  centered  front  other \_\_\_\_\_

STEERING BLOCK:  inline  trailing

CAMBER, left \_\_\_\_\_ right \_\_\_\_\_  
 TOE-IN: \_\_\_\_\_° TOE-OUT: \_\_\_\_\_°

### FRONT SPRINGS

SPRINGS:  .018  .020  .022  .024  other \_\_\_\_\_  
 KINGPIN:  STD  other \_\_\_\_\_

1) shim qty, thickness: \_\_\_\_\_  
 2) shim qty, thickness: \_\_\_\_\_  
 3) shim qty, thickness: \_\_\_\_\_  
 4) front ride height spacers: \_\_\_\_\_

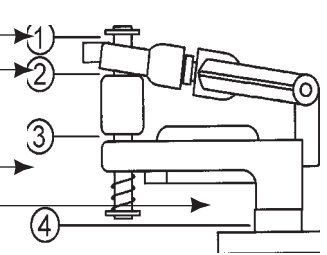

### REAR SUSPENSION

AXLE HEIGHT ADJUSTER:  
 4-up  1-up  2-up  #3  2-down  1-down  4-down



T-BAR THICKNESS:  STD  other \_\_\_\_\_

### SHOCKS

CENTER SHOCK:  STD VCS  other \_\_\_\_\_  
 OIL: \_\_\_\_\_ WT  
 SPRING: \_\_\_\_\_ PISTON:  #1  #2  #3  
 PRELOAD SPACERS: \_\_\_\_\_  
 SIDE SHOCKS:  STD VCS  other \_\_\_\_\_  
 Left OIL: \_\_\_\_\_ WT Right OIL: \_\_\_\_\_ WT  
 Left SPRING: \_\_\_\_\_ Right SPRING: \_\_\_\_\_

### WHEELS & TIRES

WHEELS & TIRES	FRONT	REAR
TIRE TYPE		
WHEELS		
TIRE DIA		
STAGGER		
CAR WIDTH		

TWEAK SETTINGS:  
 oz.  (front)  oz.  
 oz.  (rear)  oz.

SHADE IN AMOUNT OF TIRE TREATMENT

TIRE TREATMENT TYPE: \_\_\_\_\_  
 REAR AXLE:  STD  other \_\_\_\_\_

### OTHER

CHASSIS:  STD  other \_\_\_\_\_  
 CAR BODY: \_\_\_\_\_ WING/SPOILER: \_\_\_\_\_  
 MOTOR: \_\_\_\_\_ PINION: \_\_\_\_\_ SPUR GEAR: \_\_\_\_\_  
 BATTERIES: \_\_\_\_\_  
 INDICATE BATTERY PACK PLACEMENT:



OVERALL WEIGHT: \_\_\_\_\_

### GENERAL

TRACK CONDITIONS:  
 carpet  asphalt  concrete  
 track length: \_\_\_\_\_  
 high traction  med. traction  low traction  
 artificial (describe): \_\_\_\_\_  
 other: \_\_\_\_\_

RACE COMMENTS/FINISH:  
 \_\_\_\_\_  
 \_\_\_\_\_  
 \_\_\_\_\_

CAR COMMENTS/HANDLING:  
 \_\_\_\_\_  
 \_\_\_\_\_  
 \_\_\_\_\_